

MES 2008 Errata – Student Manual

19 April 2009

Replace referenced paragraphs, figures, and homework questions with the following. Changes to text are underlined for clarity.

Introduction

Page vi

2-6 Soldering a PL-259 Connector to coax cable

Chapter 1

Insert Paragraph 3a

When scientists were first discovering the properties of electricity in the 19th century, they defined current as the flow of positive charge, flowing from a positive source (point of generation) to a negative sink (point of consumption). In the early 20th century, Robert Millikan established the fact that electrons actually carry negative charge, but the conventions had already been established: current is defined to flow from positive to negative, even though the electrons themselves flow from negative to positive. This can confuse the student – just remember that engineers almost always discuss current, so the positive-to-negative convention is routinely used.

Chapter 1

Paragraph 6

The simpler of the two basic types of circuits is the series circuit. With the series electrical circuit there is only one path through which the electricity can flow. Although this type of circuit is commonly used on boats, it has a problem in that it can only effectively be used to service one electrical appliance at a time. Take a look at the illustration in Figure 1-1, which shows a boat cabin light that is serviced by a series circuit. Notice that the electricity flows from the battery through a switch to the light and back to the battery in a continuous circle. The light, which we will call the electrical load, is in series with the battery in this circuit. Now take a look at the illustration in Figure 1-2. In this illustration several cabin lights are connected in series with the battery. In this situation the electricity must flow through each light in turn until it can return back to the battery. The basic problem with this circuit is that as the electricity goes about doing its work making the light bulb glow it will be depleted in the process; with the addition of each successive light bulb, each will get less and less of the electrical energy. The light emitted by any one bulb gets dimmer and dimmer in the process. There is another inherent problem with this circuit. If something should happen to one of the light bulbs, say its filament burns out, the circuit would be broken or become open and none of the lights would come on. Although this is a good circuit to use with a single electrical appliance, you can see it is not so good to use with multiple appliances.

Chapter 1

Paragraph 21

Change James Watts to James Watt in two places.

Chapter 1
Figure 1-12

Caption: Measuring Voltage at Load

Chapter 1
Figure 1-14

Caption: Measuring Voltage Drop. Self-test: what is wrong with this picture?

Chapter 1
Paragraph 47

Measuring Amperage. Let's look at something else you can do with your multimeter—that's measuring the amount of amperage in a circuit. You learned that to measure voltage you connected the multimeter in parallel with the circuit. Unlike measuring voltage, to measure amperage you must connect the multimeter in series with the circuit. Here's how this is done. First, make sure the circuit you wish to measure is turned off. This is important because in the next step you must break the circuit in order to connect the multimeter. If the circuit was on when you make the break you would run the risk of shorting out the circuit or receiving an electrical shock. Next make sure the red lead of the multimeter is in the appropriate meter socket for measuring amperage. On most meters this will be the 10- or 20-amp meter socket. See Figure 1-16. The black test lead should remain in the COM or "-" socket. If you have an auto-ranging meter all you need to do is select AC or DC to make the measurement. If your meter is not auto-ranging you will need to also select the appropriate scale anticipated for your reading. Now, disconnect a wire at the point where you wish to measure the amperage and attach the red test lead to the terminal or wire closest to the battery (usually the wire you disconnected) and attach the black test lead to the other wire on the bad side of the circuit. Now turn the circuit on and make the measurement. The points to remember in measuring amperage are: 1) the multimeter must be connected in series with the circuit, 2) the circuit to be measured or tested must be turned off before making any disconnection in order to attach the meter test leads, and 3) the meter positive test lead must be connected to the proper meter socket for the level of amperage to be measured.

Chapter 1
Figure 1-19

Magnetic Field Associated with a Coil

Chapter 1
Homework Question #4

4. In a series circuit:

- a. the same current always flows through each device.
 - b. the same voltage is always across each device.
 - c. if one light is burned out the others remain on.
 - d. the electricity flows through multiple paths.
-

Chapter 1
Homework Question #5

5. In a parallel circuit:

- a. the same current always flows through each device.
 - b. the same voltage is always across each device.
 - c. if one light is fails, the other lights will fail.
 - d. the electricity flows through a single path.
-

Chapter 1
Homework Question #12

12. When measuring current, the multimeter is placed:

Chapter 1
Homework Question #15

15. What voltage is measured across a high resistance connection?

- a. Zero voltage
 - b. Voltage drop
 - c. Battery voltage
 - d. Double battery voltage
-

Chapter 1
Homework Question #18

18. The electrical measurement unit of the rate of dong work is:

Chapter 1
Homework Question #19

19. An electric current flowing through a conductor produces:

Chapter 2
Figure 2-1A

Figure 2-1A Wires #16 (top) to #10 (bottom)

Chapter 2
Figure 2-1B

Figure 2-1B Wires #2 (top) to #10 (bottom)

Chapter 2
Table 2-3

Delete entries for 16 ga. wiring at 15 amperes (29 feet) and for 14 ga. wiring at 20 amperes (35 feet).

Chapter 2
Paragraph 28

Delete the leading sentence to read:

For color coding of AC wiring, the “hot” leg is either black or red. Usually the black identifies the hot leg for 120-volt service, and the red identifies the second hot leg of a 3-wire 120/240-volt wiring system. The neutral leg is white or natural gray, and the safety ground is green.

Chapter 2
Paragraph 70

All AC outlets in the head, the galley, machine spaces, engine room and on the weather deck (outside exposed area) must be protected by a ground fault circuit interrupter (GFCI) device, which also serves as AC outlet. GFCI outlets will open the circuit and interrupt current flow whenever resistance between ground and the ungrounded conductor drops below 25,000 ohms. The GFCI is a safety device that instantly opens an AC circuit when a person touches the frame or metal enclosure of a faulty appliance, or a “hot” conductor, and is at the same time making contact with a ground. The GFCI outlets on the weather deck must be covered by waterproof covers when not in use.

Chapter 2
Paragraph 71

Leakage current as low as 5 milliamperes (5/1000 amperes) will trip the device. While this current flow through the body is not comfortable, it is not lethal and is an immediate warning that there is a potential danger. GFCI outlets serve to protect people, not necessarily equipment, from a lethal shock. GFCI outlets can be easily recognized by the test and reset buttons on the face plate. In some cases one GFCI outlet can provide GFCI protection to other conventional outlets downstream from it. In this case the GFCI outlet must be the first outlet in the circuit. Although not required, a good practice is for all outlets on a boat to be protected by a GFCI device. A long extension cord should not be plugged into a GFCI, nor should long wiring runs be fed from a GFCI, because the capacitive leakage to the green wire and to surrounding structures may cause nuisance tripping. The GFCI device should be within 30 feet of the appliance.

Chapter 2
Figure 2-9

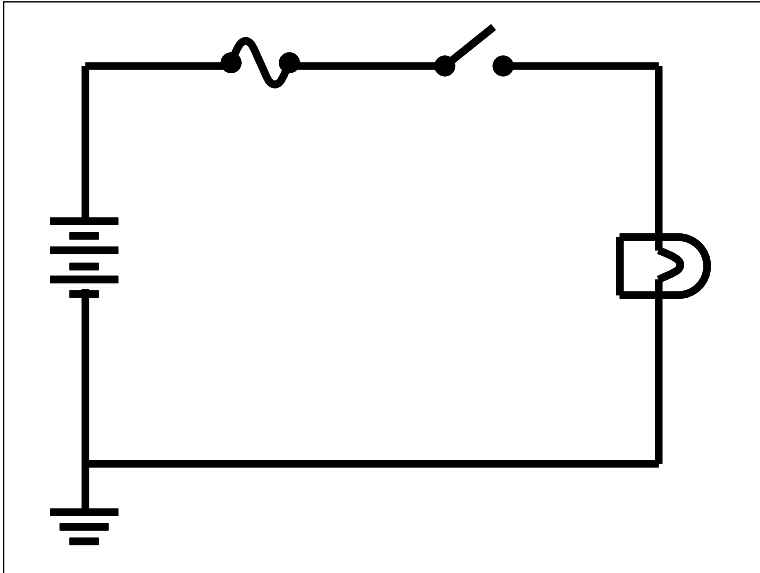

Chapter 2
Paragraph 90

Figure 3-7 is a typical-12-volt DC wiring diagram. It is both color coded to show wire use and annotated to show wire size. This figure emphasizes wire size and color, and switches. Only switches and a fuse are illustrated by their symbol; components (to include batteries) are shown as “black boxes,” not by their symbols. Note the use of dots to show connected wires. Wires crossing without dots are not connected to each other. Figures 4-4 and 4-5 in Chapter 4 show the AC wiring of either an isolation transformer or a galvanic isolator between the boat’s service entrance and the power panel. It uses symbols for connectors, circuit breakers, and boat ground. It also has the ground wire colored green to emphasize the safety ground.

Chapter 2
Homework Question #12

12. Stranded copper conductors provide for:

- a. higher current flow in smaller wires.
 - b. better insulation.
 - c. resistance to failure due to vibration.
 - d. better electrical connection to screws and studs.
-

Chapter 2
Homework Question #13

13. Crimp-type wire terminal lugs should be:

- a. full circle or captive spade type.
- b. U-shaped (plain spade) for easy removal.
- c. avoided because of cost and high resistance.
- d. crimped firmly with pliers.

Chapter 2
Homework Question #19

19. GFCI outlets trip at:

- a. 5 mA.
- b. 10 mA.
- c. 15 mA.
- d. 20 mA.

Chapter 3
Paragraph 23

Flooded-cell battery construction is optimized for intended use: starting, deep-cycle, or dual-purpose. Deep-cycle and dual-purpose flooded-cell batteries require periodic inspection and topping off of their cells with distilled water. For this reason, these batteries are generally called “accessible.” Many starting flooded-cell batteries are “non-accessible” as their cells cannot be opened and water cannot be added to them.

Chapter 3
Paragraph 33

Other advantages of AGM batteries are: spill proof and leak proof. A disadvantage of AGM batteries is that they are capable of fewer discharge cycles than gelled electrolyte battery technologies.

Chapter 3
Paragraph 65

A supply of instantly available energy can be stored in chemical form in a storage battery. As previously covered, the most common marine storage battery is the lead-acid variety. To replace the depleted energy of the storage battery, a supply of direct current must be pumped back (reverse flow) into the storage battery. More charge (ampere hours) must be pumped back into the battery during charging than removed during its use. Flooded-cell batteries require approximately 115 to 120%; VRLA batteries require approximately 105 to 115%. The two basic battery charging systems aboard boats are an alternator with rectifier and an AC to DC converter (battery charger).

Chapter 3
Homework Question #15

15. Flooded-cell batteries require charging current to:

- a. equal 100% of charge removed from battery.
- b. equal 105% to 115% of charge removed from battery.
- c. equal 115% to 120% of charge removed from battery.
- d. equal 120% to 140% of charge removed from battery.

Chapter 3
Homework Question #21

21. The maximum lead-acid chemistry charge rate in amperes should not exceed _____ percent of the rated ampere-hour capacity.

- a. 10
- b. 20-40
- c. 40-50
- d. 60

Chapter 4
Paragraph 7

Polarity. In AC wiring there are normally three polarized wires. The hot wire is normally black, the neutral wire is white, and the ground wire is either bare or green. Polarity in AC circuits is even more critical than it is in DC circuits. Reversing the hot (black) wire with the neutral (white) wire can destroy polarity-sensitive equipment such as motors, TVs, and electronic equipment.

Chapter 4
Paragraph 21

Ampere (VA) Rating - The AC power formula differs from that used for direct current. Power is reduced whenever current and voltage are not in phase (normal for AC motors). Occasionally the rating of a piece of AC equipment is given in volt-amperes (VA), which is the product of the voltage and the current. The power in watts is usually a large fraction of (always less than) the VA value, but this is beyond the scope of this course and will not be discussed further.

Chapter 4
Paragraph 34

Nominal shoreside power is 120/240 volts 60 Hz AC, even though the service cords, outlets, and plugs are called 125 or 125/250V. Boats under 30 feet normally use a single 30-amp service cord to provide all their shoreside power. Most boats between 30 and 40 feet use two 30-amp service cords to provide more current for their increased demand for shoreside power. Using two 30-amp service cords requires two 30-amp receptacles. If your electric demand is held down to less than 30 amps, you can configure the circuit breakers on your AC panel to use only one 30-amp service cord. If total current you require is less than 50 amps or shoreside power receptacle is 50 amps, a splitter is required to connect two 30-amp cords into a 50-amp receptacle. Even though two 30-amp service cords are used, total current available is limited to 50 amps. Boats over 40 feet normally use one or two 50-amp, 120-volt service cables or 50-amp, 125/250-volt service cables.

Chapter 4
Paragraph 46

Take care not to overload a shoreside outlet of lesser ampacity than that of your vessel. Do not parallel two shoreside outlets for added current. This can be a serious hazard. Reverse Y or Smart Y adapters are designed to provide 50A 125/250V AC from two 30A 125 V shore power outlets. Current will flow only after both plugs are connected, are of opposite phase, and correctly polarized (this is the standard configuration of dockside service – the Smart Y will only function if the service is correctly configured). Maximum current available is limited to 30A per leg (limited by dockside outlets and circuit breakers) for a total of 60A at 120V.

Chapter 4
Paragraph 49

The power inlets on a boat are sized for the service cord and are normally one or two 30A, 125V male plugs into which the service cords are connected. Boats requiring more power will have one or two 50A, 125V or 50A, 125/250V male plugs. When service cords are not connected, the weatherproof covers on these inlets should be closed to prevent corrosion of the male prongs. **CAUTION** – When connecting shore power to a boat 1) turn off all circuit breakers on the boat's AC power panel, 2) connect the service cord(s) to the boat's power inlet(s), 3) make sure that the shore power circuit breakers are off, 4) connect the service cords to the dockside outlets, 5) turn on the dockside circuit breakers, 6) turn on master circuit breakers at the AC power panel, 7) check polarity indicator on boat's AC power panel and disconnect power cable if polarity is reverse and 8) turn on branch circuit breakers as required. [Delete the last sentence.]

Chapter 4
Figure 4-5

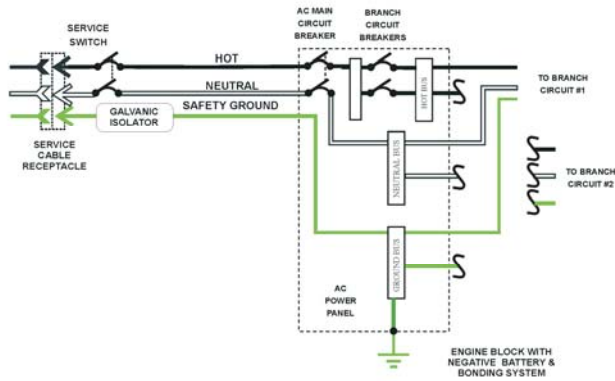

Chapter 4
Paragraph 62

Note: The output of some inverters is a modified sine wave, rather than a sine wave, and may not run some sensitive equipment. In addition, the peak voltages may not be high enough to allow proper operation of the chargers for some battery-operated equipment. Tools using higher voltage batteries may fit in this category. True sine wave (TSW) inverters are more expensive and will run all AC loads; they are best for sensitive electronic equipment. Modified sine wave (MSW) inverters (that do not provide pure sine wave power) are less expensive and more popular. Most common appliances will operate satisfactorily on MSW inverter; however, sensitive electronic equipment may not operate satisfactorily or may even be damaged.

Chapter 4
Homework Question #1

1. **Nominal voltage for AC in the United States is:**
- 100 volts.
 - 105 volts.
 - 120 volts.
 - 130 volts.

Chapter 4
Homework Question #4

4. **Service cord ratings are based on _____ feet length of cable.**
- 25
 - 50
 - 75
 - 100
-

Chapter 4

Homework Question #10

- 10. A high-quality inverter provides 60 Hz _____ AC power.**
- square wave.
 - modified true wave.
 - true sine wave
 - discrete cosine transformation

Chapter 4

Homework Question #18

- 18. The galvanic isolator should be installed in _____ wire.**
- series with the green ground
 - parallel with the green ground
 - series with the white neutral
 - parallel with the white neutral

Chapter 5

Homework Question #1

- 1. For significant galvanic corrosion to take place the two metal electrodes must:**
- be identical.
 - be close together on the galvanic scale.
 - be far apart on the galvanic scale.
 - be of different polarities on the galvanic scale.

Chapter 5

Homework Question #3

- 3. The first sign of galvanic corrosion is _____ the waterline.**
- blistered paint on metal above
 - blistered paint on metal below
 - a powdery substance on metal above
 - a powdery substance on metal below

Chapter 5

Homework Question #7

- 7. A galvanic isolator prevents DC current between boats and installed in series with the:**
- battery negative lead to ground.
 - battery positive lead.
 - shore power ground wire.
 - shore power neutral wire.
-

Chapter 5
Homework Question #8

- 8. Stray current corrosion is normally caused by:**
- stray AC current between black and green wires.
 - stray DC current from the boat's bonding system.
 - stray AC current from a source external to the boat.
 - stray current either from the boat's DC battery or from an external source of DC.
-

Chapter 5
Homework Question #9

- 9. DC stray current corrodes which electrode?**
- The more passive or noble one.
 - The more active or less noble one.
 - The one that current flows from.
 - The one that current flows to.
-

Chapter 5
Homework Question #12

- 12. The corrosion of aluminum castings for outboards and outdrives can be prevented by:**
- installing sacrificial anodes below the waterline.
 - painting the aluminum with copper-based paint.
 - connecting the shoreside AC green wire to the DC ground.
 - doing nothing since they will not corrode.
-

Chapter 5
Homework Question #13

- 13. Corrosion due to stray current flow in wiring systems can be eliminated or reduced by:**
-

Chapter 5
Homework Question #14

- 14. With stray current flow of alternating current:**
- only the base metals will be corroded.
 - only noble metals will be corroded.
 - any metal carrying current will be corroded.
 - no corrosion will take place.
-

Chapter 6
Homework Question #6

- 6. The lightning protection system for a power boat normally uses a:**
- fiberglass antenna grounded to the engine block(s).
 - fiberglass antenna connected to a water terminal.
 - metal whip antenna grounded to the engine block(s).
 - metal whip antenna connected to a water terminal.

Chapter 6
Homework Question #7

- 7. The lightning protection system for a sailboat normally uses the:**
- VHF antenna grounded to the engine block.
 - VHF antenna connected to the keel.
 - mast grounded to the engine block.
 - mast connected to the keel.

Chapter 6
Homework Question #8

- 8. Precautions for personnel during a lightning storm include:**
- remaining inside the boat and avoiding unnecessary contact with metal surfaces.
 - getting in the water and holding onto any metal surface.
 - staying out of the water and holding onto any metal surface.
 - remaining inside the boat and holding onto any metal surface.

Chapter 7
Paragraph 2

This chapter is divided into four major sections: basic tools, testing of DC circuits, testing of AC circuits, and electrical interference. The section on basic tools covers multimeters and suggested wiring and miscellaneous tools; some simple do-it-yourself test tools are then described. The section on DC circuits starts by discussing testing of batteries, alternator checks, and testing of battery chargers. Then it covers troubleshooting of lighting systems and getting power to DC electrical systems. The section on AC circuits includes both testing and troubleshooting. The last section is on electrical interference. First it covers the sources of electrical interference and outlines techniques to locate on board interference. Then it discusses both interference suppression and mitigation techniques.

Chapter 7
Paragraph 19

Screwdrivers – Four screwdrivers with approximately 4-inch shaft are recommended for electrical work. You will need 3/16- and 1/4-inch blade screwdrivers and #1 and #2 Phillips screwdrivers. You will also need two small screwdrivers, one with a 1/8-inch blade and a #1 Phillips.

Chapter 7
Paragraph 31

Quick Test of Alternator – With the engine and battery charger off measure the battery voltage at the DC output of the alternator. Then start the engine; if the voltage increases (you are now measuring battery alternator output voltage, not battery voltage) the alternator is probably working satisfactorily. If the voltage remains the same, there is a problem with the alternator system. CAUTION – Watch out for the moving alternator belt when the engine is started and running.

Chapter 7
Paragraph 53

If you have DC power to the device, then check the device's cables. Visually check all cable connections for corrosion. If corrosion is found, spray both the cable and equipment connectors with CRC's QD Electronic Cleaner or equivalent. Then make sure that the connections are properly mated and secured. This may restore the device to full capability. If it does not, now is the time to either call for a qualified marine electronic technician or take the electronic device to a technician.

Chapter 7
Paragraph 120

Coil Polarity. It sometimes happens, with both original installations and replacements, that ignition coils are installed with reverse polarity. Operation under these conditions may not immediately show up as impaired engine performance, but higher than normal interference will occur. Therefore, a check of polarity should be part of any investigation of interference.

Chapter 7
Homework Question #1

- 1. The disadvantage of an analog multimeter, compared to a digital multimeter, is:**
- high cost.
 - a difficult to read measured value.
 - larger size and heavier weight.
 - the requirement that it be plugged into AC power.

Chapter 7
Homework Question #2

- 2. The advantage of a digital multimeter, compared to an analog multimeter, is:**
- low cost.
 - an easy to read measured value.
 - smaller size and lighter weight.
 - that it uses internal batteries.

Chapter 7
Homework Question #3

3. The plastic grips on cutters are for:

- a. aesthetics.
 - b. electrical insulation.
 - c. cushion.
 - d. identification.
-

Chapter 7

Homework Question #4

4. A hydrometer test can be conducted on which battery?

- a. Serviceable lead-acid.
 - b. Maintenance-free lead-acid.
 - c. Gelled battery.
 - d. AGM battery.
-

Chapter 7

Homework Question #8

8. If a boat light does not come on when its switch is turned on, first expect:

- a. a blown fuse.
 - b. corroded contacts between the light bulb and its socket.
 - c. a defective circuit breaker or switch.
 - d. a burned out light bulb.
-

Chapter 7

Homework Question #10

10. AC outlets and GFCIs are best tested with:

- a. a voltmeter.
 - b. a current meter.
 - c. an outlet tester.
 - d. a hydrometer.
-

Chapter 7

Homework Question #18

18. The level of ignition system interference can be reduced by:

- a. installing a coaxial capacitor in each spark plug wire.
 - b. using capacitor cable spark plug wires or choke spark plugs.
 - c. using choke cable spark plug wires or capacitor spark plugs.
 - d. using resistor cable spark plug wires or resistor spark plugs.
-

Chapter 7

Homework Question #20

20. When equipment is suspected, the first mitigation step is normally to:

- a. construct a copper screen cage around the equipment.
 - b. place interference chokes in series with the equipment DC wires.
 - c. attach two capacitors from each equipment DC power input terminal to ground.
 - d. connect the equipment's metal case to the boat's grounding/bonding system.
-